

AREDN® Network Beginner's Guide - for the Absolute Newbie

What it's all about

By loading the AREDN®¹ firmware in a outdoor wireless access point, you can join a ham radio network. It's like the Internet but runs on ham radio frequencies, mostly in the 2.4, 3.4, and 5.8 GHz bands.

By joining this network you can find and use all sorts of applications (known as "services"). Anything running on a server, like weather stations, web sites showing site conditions, email servers, etc can be provided as a service. There are also services that don't rely on a browser: video streams, chat servers, VOIP PBXes, etc. The network can also be used to connect Winlink stations, Dstar and DMR repeaters, and Allstar devices.

Pretty much any kind of service you can put on the Internet you can put on the AREDN hamnet, subject to the restrictions of the ham radio regulations (FCC "Part 97").

Getting started

The network is growing steadily, but the number of accessible nodes in your area can range from plentiful to none within hundreds of miles.

RF access to the network

How do you find out where the nearest network node is? There are several ways:

- Check the mesh map at arednmesh.org. If you don't find one near your QTH, don't despair; the map only shows a fraction of the nodes on the air, as it requires the owner to manually register the node, and not everyone does that. If you're in any of the areas listed in Appendix A, there are realtime network maps that can help you determine if there's a node in your area.
- Register an account on arednmesh.org and see if there's a Regional Forum for your area. Ask in there for local information.
 - If you don't find a regional forum for your area, get it started by asking the webmaster, Randy WU2S to create one for you. Search for his callsign using the search function, and by finding it you'll be able to drop him a note. Once it's created, create a post mentioning you'd like to get started and asking if there's any activity near you.
- Ask around your local ham club or on a local net.

1 AREDN® is a registered trademark of the Amateur Radio Emergency Data Network, Inc.

AREDN® Network Beginner's Guide - for the Absolute Newbie

These network nodes behave very much like handie-talkies. That is, they're low-power and line of sight, so you typically end up talking to a network node on a hilltop, mountaintop or some other elevated location (e.g. water tower).

So if you determine there is a local node, how do you find out if you can reach it?

For these devices, line of sight is REALLY line of sight; they don't do trees well at all. There are a number of on-line LOS calculators, ranging from simple to use to really complex. A simple one is at <https://heywhatsthat.com>. By entering your location, expected elevation of your node, and naming it, the site will generate a coverage plot for you. You can do this for your QTH and/or any existing local nodes.

See Appendix B for other tools.

Note - these plots assume omnidirectional coverage, and most all network nodes on hilltops use directional sector antennas. But the plots will let you know if there's a possibility of connecting via RF to that node.

Alternate access to the network

If after doing your research you find that you don't have any RF path to the network, don't despair; there is an alternative. The nodes have the capability of 'tunneling' over the Internet to another node. While this isn't a 'real' radio connection it will let you get on the network until such time as the network has grown into your area.

In order to establish a tunnel, you'll need an additional piece of network equipment beyond the node itself. The current preferred device is the Mikrotik hAP AC Lite router which when running AREDN® firmware will provide your node access to the Internet (plus a host of other really useful features when running a ham network in your shack). Current price on Amazon is about \$50.

Recommended equipment

Note: these recommendations are for a base station; recommendations for network nodes on hilltops are likely to be different and beyond the scope of this introductory article.

In order to ensure good performance you need a strong link into the network. Like most other ham radio activities more gain is better than less. And even if you have two nodes within range the node's routing software will always pick the strongest one as your path into the network. So omni antennas are discouraged and dish antennas greatly preferred.

AREDN® Network Beginner's Guide - for the Absolute Newbie

All of the equipment using dish antennas supported by AREDN® use electronics integrated into the dish feedpoint: two transceivers, two modems, and an embedded computer with RAM, ROM and a network interface. They are all POE-enabled (Power Over Ethernet). This avoids having to run both a network cable and a power cable up the mast to the node. A web interface is used to control and configure the device.

Obviously your equipment will need to be on the same band as the node you want to connect to. If there are both 2 GHz and 5 GHz nodes equidistant from you with similar path characteristics, choose 5 GHz; the band is quieter, there's more bandwidth, more channels and the gear is about the same cost (and in some cases noticeably less).

Fortunately AREDN® now supports over 60 devices (including those added in the nightly builds) so there are many options when choosing what to buy.

The Mikrotik dishes may be slightly less durable than the equivalent Ubiquiti so if you live where there's severe icing that may be an issue. Reportedly the Mikrotik receivers may be slightly hotter (more sensitive) than the Ubiquiti ones. And the Mikrotik dishes are lighter, making them more suitable for portable work (e.g., go boxes). But both brands work well.

Important note #1 - The older models of equipment have less flash memory & RAM than current versions. The latest AREDN® firmware runs on these devices but there are not enough resources to run things like tunnels. And as time goes on the AREDN firmware grows slowly. At some point in time it will no longer fit in the available resources of older devices.

Don't buy any used equipment unless you know it has at least 8 MB of flash and 64 MB of RAM and is "MIMO". The AREDN® team has flagged those devices that are no longer recommended for new purchase in their Supported Platform Matrix: <https://www.arednmesh.org/content/supported-platform-matrix>

Important note #2 - Do not stand in front of the radio for extended periods of time when it's powered on. NEVER look into the focus of the radio when it's powered on. **These small dishes have 80 - 100 watts of ERP at 5.8 Ghz! The Mikrotik Basebox 2 has 30 dBm of power output. When fed to a Mikrotik 30dB gain dish, that's 1 KW of ERP. Use caution!**

AREDN® Network Beginner's Guide - for the Absolute Newbie

Equipment update -

Previously the smaller Ubiquiti Nanostation M5 and TP-Link CPE-510 could be used for 5 GHz links up to about 10 miles (assuming line of sight). However, the FCC recently changed the regulations, allowing Part 15 unlicensed wireless users to co-occupy the 5 GHz channels that were previously solely amateur radio. That means that over time the noise floor in the 5 GHz Part 97 channels will gradually rise. Recommend using one of the higher-gain devices shown below to 'future-proof' your installation.

5 GHz Options

Ubiquiti

Ubiquiti provides 3 models of 5 GHz devices with dish antennas, with increasing amounts of gain:



PBE-M5-400

Powerbeam PBE-M5-300 (the 300 is the dish diameter in millimeters) - 22 dBi gain, 2.65 pounds

Powerbeam PBE-M5-400 - 25 dBi gain, 3.87 pounds

Powerbeam PBE-M5-620 - 29 dBi gain, 14.11 pounds

If you aren't certain, choose the PBE-M5-400 for the additional gain, unless you think you need the additional gain of the 620 and can afford it. But it's big and heavy and will strike fear into the hearts of your neighbors.

AREDN® Network Beginner's Guide - for the Absolute Newbie

Mikrotik



RBLHG-5nD - Routerboard Lite Head Grid - 390 mm dia., 24.5 dBi gain. 1.3 pounds.

RBLHG-5HPnD-XL - Routerboard Lite Head Grid High Power - 550 mm dia, 27 dBi gain. 2.1 pounds.



QRT 5

Flat panel antenna - Approx. 11" square. 24 dBi gain, 10° beamwidth.



LDF 5 - Light Data Feed. This is a unique device. By itself, it only has 9 dBi gain. But it's made to be mounted in a standard 40 mm dish mount.

AREDN® Network Beginner's Guide - for the Absolute Newbie



That means any dish - including a repurposed DishTV or DirectTV dish. Those typically will provide overall gain of 22-25 dBi.

These are perfect if you live in an area with a restrictive HOA or CC&R. Your neighbors will never notice the dish isn't pointed up at some synchronous satellite! About \$50-60 on Amazon

The LDF 2 for 2 GHz is now also supported by AREDN. The dish will yield ~4 dB less gain than when used with the LDF 5.

The universal mount is available for about seven dollars from Amazon (<https://amzn.to/34QCvSj>).

2 GHz Options

If your only accessible local node is on 2 GHz, you still have several options. Because of the lower frequency, dishes will be larger for the same gain.

Ubiquiti



Powerbeam PBE-M2-400 - 420 mm,
18 dBi gain, 3.96 pounds

AREDN® Network Beginner's Guide - for the Absolute Newbie

Mikrotik

The Mikrotik RBLHG-2nD and RBLHG-2nD-XL 2 GHz are lightweight, affordable radios.

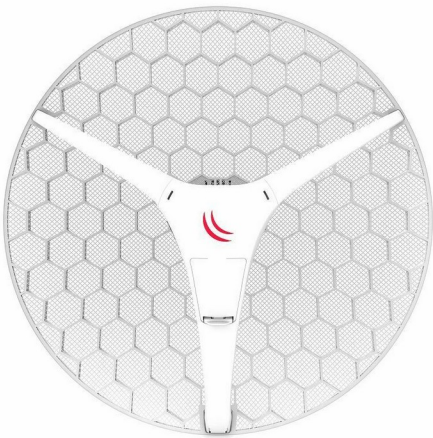

Mikrotik RBLHG-2nD – 18 dBi,
1.25 pounds



Mikrotik RBLHG-2nDXL – 21 dBi,
2.1 pounds

AREDN® Network Beginner's Guide - for the Absolute Newbie

Extra Goodies



The Mikrotik hAP AC Lite (RB952Ui-5ac2nD) is a five-port router. It provides a seamless method for integrating the ham radio network into your ham shack network.

When running AREDN® firmware, it provides:

- One port to connect to your outside node (a "DtD" - Device to Device port). POE power for the node can be enabled on this port.

- One port to connect to your home router, for Internet access [necessary if you need to tunnel your node to another node for network access].

- Three ports that can be used to connect your shack PC to both the Internet and the mesh network (eliminating the need for two computers in the shack, one on each network), with two spare ports for things like cameras, VOIP phones or Raspberry Pis.

Over and above those features, the hAP AC Lite has two internal radios, a 2.4 and a 5.8 GHz. The 2.4 GHz radio can be configured as a mesh node OR as a wireless access point. The 5.8 GHz radio can be configured as a wireless access point. Having a wireless Part 15 access point on your shack's ham network is very handy - you can link your laptop or smartphone to it wirelessly and have access to both the Internet and the ham net.

And either of the internal radios can be configured as a wireless access client. This is handy if you're traveling and wind up in a hotel that charges for Internet access on a per-device basis.

AREDN® Network Beginner's Guide - for the Absolute Newbie

Configuring your node

After you have your equipment in hand, you have to install the AREDN® software, configure its settings and put it up in the air.

Installation and configuration of the AREDN® firmware is well covered in the [AREDN on-line documents](#) at arednmesh.org (See **Installing AREDN Firmware** and **Basic Radio Setup**).

Aiming

Note that the higher the gain, the narrower the beamwidth and the trickier it is to aim these dishes accurately. Fortunately, some aiming tools have recently been added to the AREDN® firmware that help greatly in setting up the dish in the correct direction (and elevation; their vertical beamwidth is as narrow as their horizontal beamwidth).

In the Charts area, you'll see a real-time SNR chart. To the left of it is the audible tuner. Select the device you're aiming at from the drop-down labeled "Selected Device".

Note - when aiming, slew the dish slowly, as the indicators (visual and audible) are slow to update.

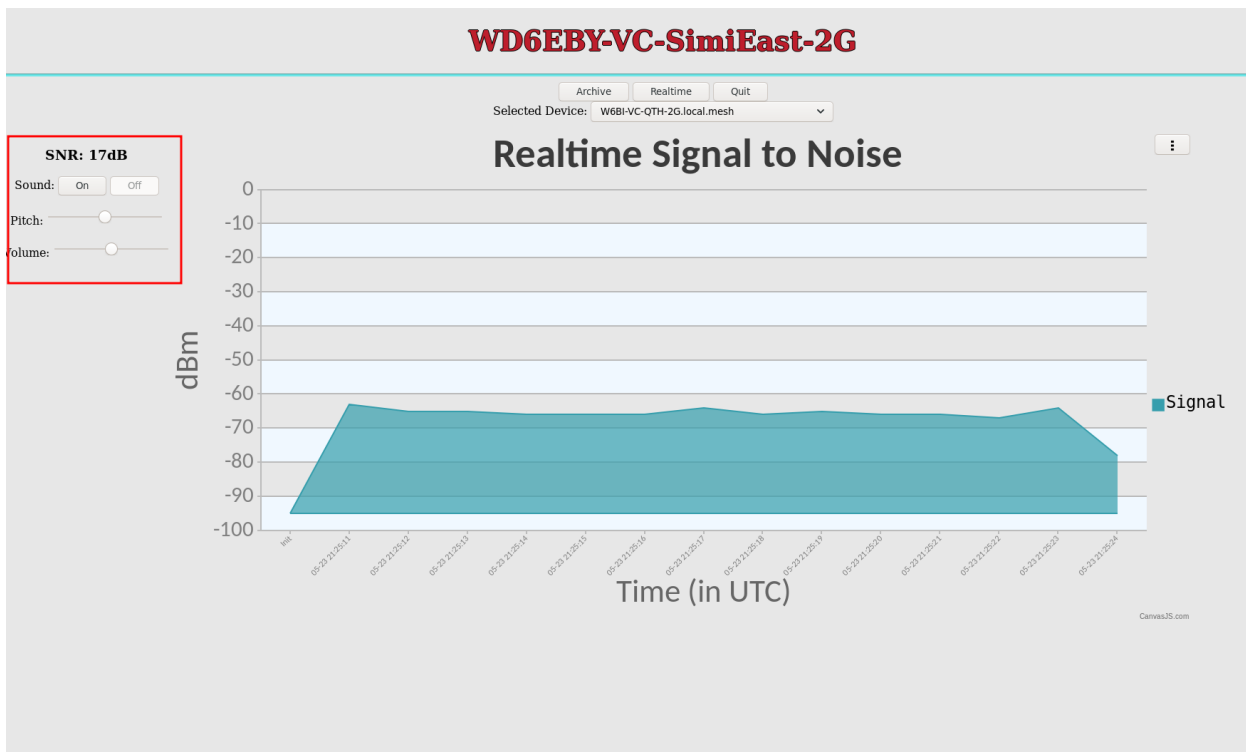

AREDN® Network Beginner's Guide - for the Absolute Newbie

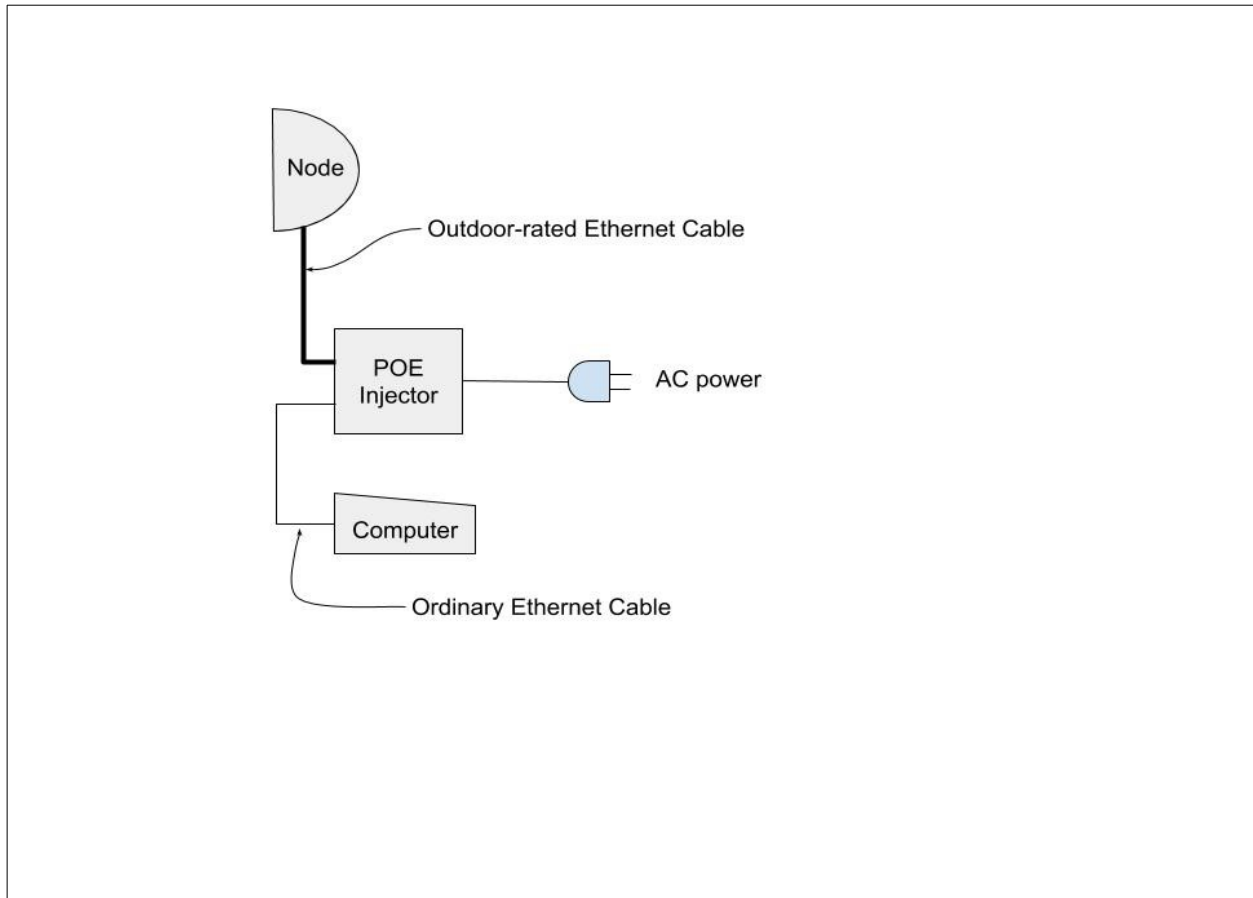
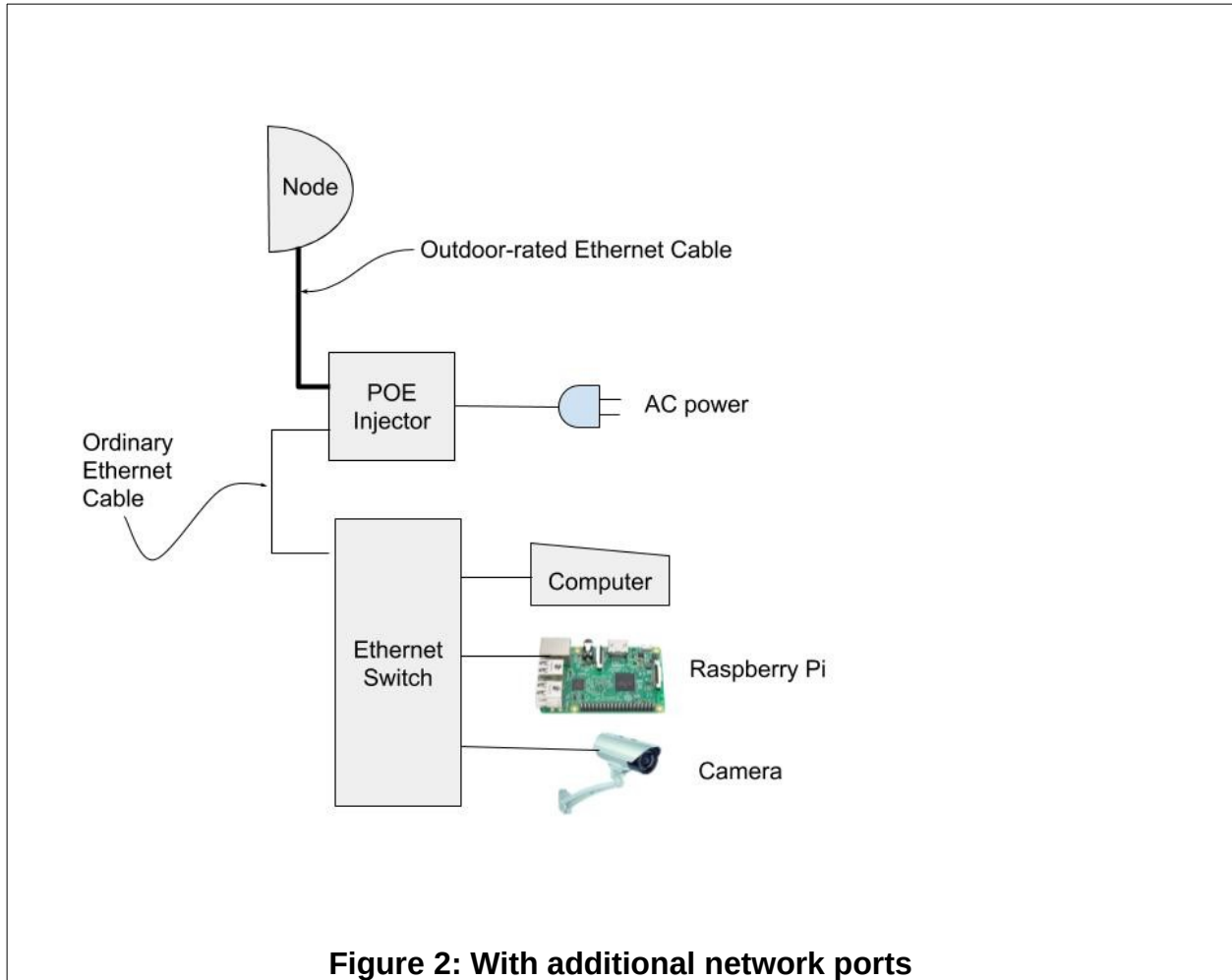

Figure 1: Basic Installation

AREDN® Network Beginner's Guide - for the Absolute Newbie



AREDN® Network Beginner's Guide - for the Absolute Newbie

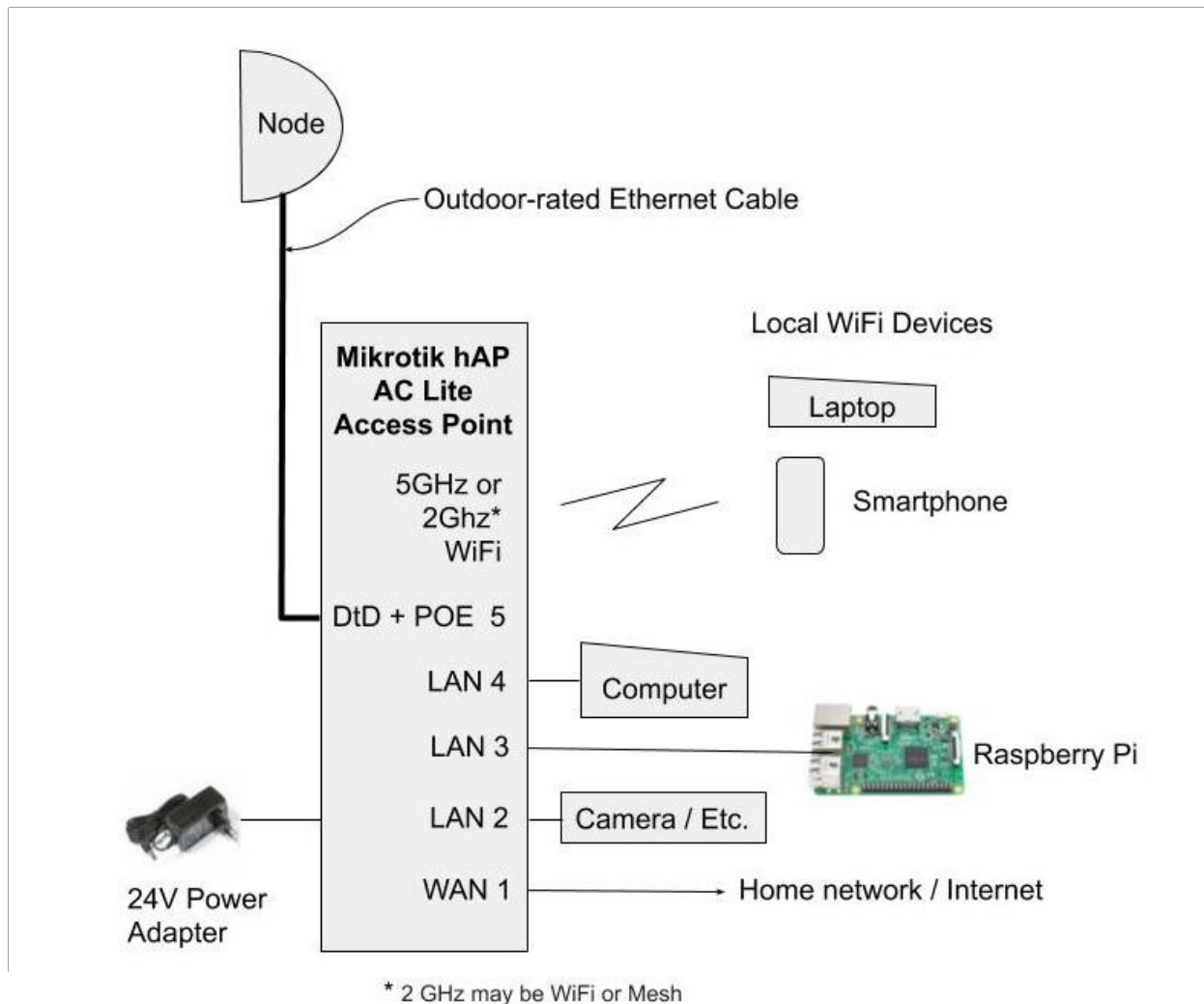

Figure 3 - Integration of a Mikrotik hAP AC Lite into the station network

All this information and much, much more is available at the AREDN web site: arednmesh.org

AREDN® Network Beginner's Guide - for the Absolute Newbie

Appendix A

Some mesh network maps available on the Internet

- Central & Southern California: <https://mapping.kg6wxc.net/meshmap>
- Yakima, WA: <http://ka7hak.thatip.net:7773/meshmap>
- Oregon: https://arden.k9rcp.net/meshmap/map_display.php
- San Francisco: <https://sfmap.xojs.org/>
- Hawaii: <http://42561.noip.us:8888/meshmap>

Appendix B

Coverage tools

- heywhatsthat.com - easy to use
- <https://ispdesign.ui.com/#/ptp> - easy to moderate
- <https://www.scadacore.com/tools/rf-path/rf-line-of-sight/> - easy
- Radio Mobile - complex
- <http://www.ve2dbe.com/english1.html>

Fresnel Zone tool

- radiofresnel.com

The Fresnel zone is how much your radio link 'spreads' between source and destination. If anything impinges into the Fresnel zone, your signal could be degraded. This tool calculates that zone for you.